

SEGA[®]

SONIC SPINNER

(non-CEC version)



Operator's Manual

SEGA AMUSEMENTS U.S.A., INC.
800 Arthur Avenue, Elk Grove Village, IL 60007-5215
Phone: 888-877-2669 FAX: 847-427-1065

Table of Contents

1.	SAFETY NOTICES	2
2.	FCC COMPLIANCE	2
3.	SETTING-UP THE GAME FOR THE DESIRED PAYOUT PERCENTAGE	3
3.1.	COINS-PER-CREDIT (SERVICE MENU SETTING 02)	3
3.2.	PRIZE DIAL (SERVICE MENU SETTING 03)	3
3.3.	SKILL LEVEL (SERVICE MENU SETTING 06).....	3
4.	SERVICE MENU:	4
5.	SONIC SPINNER ERROR CODES	6
6.	SONIC SPINNER SWITCH & OUTPUT NUMBERS	7
7.	PARTS AND PART NUMBERS	8
7.1.	EXPLODED DRAWING OF MECHANISM WITH PART NUMBERS.....	8
7.2.	MAIN CABINET WITH PARTS NUMBERS.....	9
8.	WIRING SCHEMATIC	10

1. Safety Notices

The following safety instructions apply to all game operators. We recommend that you read this page before setting-up SONIC SPINNER. Use the following safety guidelines to help protect the system from potential damage and to ensure your personal safety.

- Use with only 120 volts/60Hz
- To help prevent electric shock, plug the system power cables into properly grounded power sources. These cables are equipped with 3-prong plugs to help ensure proper grounding. Do not use adapter plugs or remove the grounding prong from a cable. If you must use an extension cable, use a 3 wire cable with properly grounded plugs.
- To help protect your system from sudden, transient increases and decreases in electrical power, use a surge suppressor, line conditioner or uninterruptible power supply (UPS).
- Do not spill food or liquid on your system.
- Do not push any objects into the openings of the system. Doing so can cause fire or electric shock by shorting out interior components.
- Keep your game far away from radiators and heat sources.
- Do not block cooling vents.
- Before working on the machine be sure to unplug it.
- Be sure to use fuses that meet the specified rating. (5A, 250V Fast-blow). Using fuses exceeding the specified rating can cause a fire and electrical shock.

2. FCC Compliance

Note: This equipment has been tested and found to comply with the limits for a Class A digital device, pursuant to Part 15 of the FCC Rules. These limits are designed to provide reasonable protection against harmful interference when the equipment is operated in a commercial environment. This equipment generates, uses, and can radiate radio frequency energy and, if not installed and used in accordance with the instructions manual, may cause harmful interference to radio communications. Operation of this equipment in a residential area is likely to cause harmful interference in which case the user will be required to correct the interference at his own expense.

3. Setting-up the Game for the Desired Payout Percentage

There are three settings that affect the game's payout percentage; the **Coins-Per-Credit** setting, **Prize Dial** setting, and the **Skill Level** setting. See Section 4 for information on how to enter and change settings in the **Service Menu**.

3.1. Coins-per-Credit (service menu setting 02)

This setting determines the number of coins that have to be inserted before a single play is initiated. SONIC SPINNER can be set from one to nine coins per single play. The game's default setting is one coin per play.

3.2. Prize Dial (service menu setting 03)

SONIC SPINNER ships with three unique Prize Dials. Use the Prize Dial to get close to your desired ticket payout and then tune the payout by adjusting the **Skill Level** setting up or down.

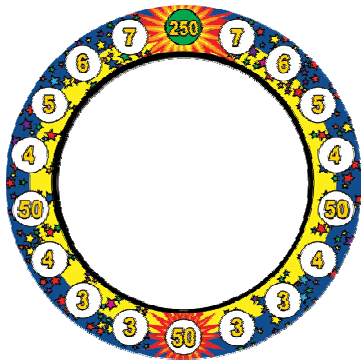

Prize Dial #1
High

Average 15 tickets
At skill setting #4
Part#: 532-30-207
(PRIZE DIAL, DIAMOND)

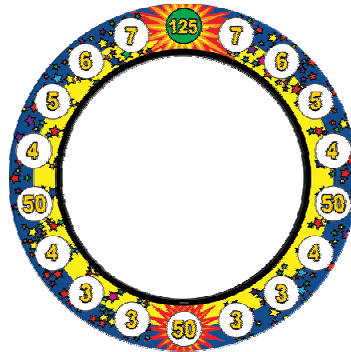

Prize Dial #2
Medium

Average 7 tickets
At skill setting #6
Part#: 532-30-206
(PRIZE DIAL, CLUB)

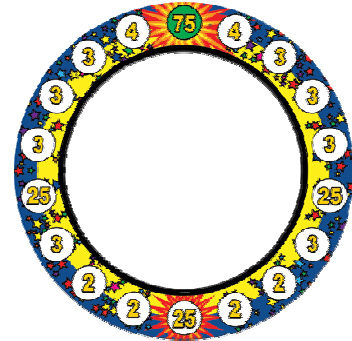

Prize Dial #3
Low

Average 4 tickets
At skill setting #6
Part#: 532-30-205
(PRIZE DIAL HEART)

3.3. Skill Level (service menu setting 06)

The skill level setting has nine increments and can be set from the easiest setting of "1" to the most difficult setting of "9." The skill settings will significantly affect the average ticket payout. Because players vary at different locations, operators will need to monitor ticket payout and adjust the difficulty level until they achieve the desired payout.

4. Service Menu:

The **Service Menu** allows operators to adjust game settings and test lamps, switches and the motor. The list of service menu items and settings starts on the next page.

The **Service Menu** buttons are located behind the top coin door. Press the “Service” button to enter the **Service Menu**. Once in the **Service Menu**, press the “Service” button again to advance to the next Service Menu item.

Service Menu items are adjusted by using the “Up” and “Down” buttons.

To exit the **Service Menu** and save setting, press the “Service” button for three seconds.

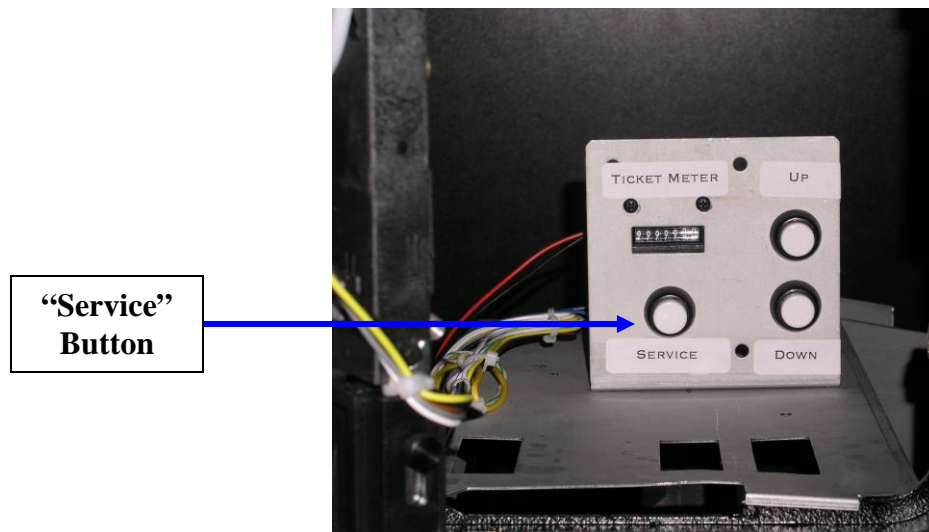

SONIC SPINNER, SERVICE Menu Items

Service Menu Item	Configuration/ Test Name	Factory Default Value	Menu Item Values & Description
01	Pay Mode	0 – Pay-for-Play	0 – Pay-for-Play 1 - Free-Play (Show/Demo) with NO Tickets Dispensed
02	Coins-per-Credit	1 Coin / Credit	1 – 9 coins per Credit
03	Prize Dial Setting	2 – Medium	1 – Prize Dial #1 - High 2 – Prize Dial #2 - Medium 3 – Prize Dial #3 - Low
04	Attract Mode	2 – Sounds, Lights & Motion	0 – No attract mode 1 – No Sound 2 – Sounds, Lights & Motion
06	Skill Level	6 - 1	1 – Easy 2 – 3 4 – 5 - Normal 6 7 - Hard 8 - 9 – Extremely Hard
19	Bill Acceptor	0 – none installed	0 – no Bill Acceptor Installed 1 – 9 Coins counted for each dollar (assumes 1- active LOW pulse per dollar)
30	Clear Credits	n/a	Clears accumulated credits
40	Switch Test	n/a	Shows switch number of any switch (including INDEX and SECTOR Optos) that is found to be “ON”. Values range from 00 – 31. A list of switch numbers can be found in Section 6.
41	Lights Test	n/a	Use UP and DOWN switches to turn the various non-prize dial lights ON and OFF. See Test 42 below for Prize Dial Lamps Test.
42	Prize Dial Lamps Test	n/a	Use UP and DOWN switches to sequentially turn Prize Dial Lamps ON. UP turns Lamps on in a Clockwise direction, DOWN in a Counter-Clockwise direction. The LED display shows the Sector Number of the Lamp currently ON. Sector Numbers start at 12 o'clock == Sector 1.
43	Display Test	n/a	Use UP and DOWN switches to turn display ON and OFF. When ON, the display shows ‘all eights’ 888
44	Motor Test	n/a	Use UP and DOWN switches to turn motor ON and OFF.
45	Sound Test	n/a	Use UP switch to exercise Sound Channel 1. Use DOWN switch to exercise Sound Channel 2
46	Ticket Dispenser Test	n/a	Depressing the DOWN switch will dispense 1 ticket. UP dispenses 5 tickets. The Ticket Meter is not advanced during this test.
98	Restore Factory Defaults	0 – keep current values	0 – keep current values 1 – Factory Default Configuration

5. SONIC SPINNER, ERROR CODES

The 3-digit display is used to show error codes during the calibration sequence, and during game play. For most errors, the actual ERROR CODEs (numbers from 00 – 99) are shown on the display. Errors detected during the Power-Up/Calibration sequence are displayed with a “C” on the display then the Error Number. Errors detected during game play are shown with “E” on the display and then the error code. The “C” and “E” arrangement allows the operator to know if the problem was detected on Power-Up/Calibration before the game play started, or was encountered during actual game play.

A couple of special “errors” are shown in an alpha-only format rather than the alphanumeric format described above. Ticket errors are shown with “tic”, and coin switch errors are shown as “Coi”. These relatively common "errors" are more easily identified with an alpha format.

ERROR CODES

Error #	Problem Area	Problem Detail	Possible Causes	Action to Reset Error Code
00 through 31	Stuck Switch	A normally OFF switch was detected as ON.	(1) Bad switch (2) Shorted cable	Determine which switch is the problem by locating it on schematic. The Error Code corresponds to the SWxx number in Section 6. Fatal Error – Game will not continue.
“tic”	Ticket Dispenser	If a ticket notch is not detected, the ticket dispenser is turned on for 3 seconds to search for the notch. If notch is not found this error is displayed. Note: Detection of this error is DISABLED when in “Show/DEMO” mode	(1) Ticket Jammed (2) Bad Ticket Dispenser/Opto	Remove jammed ticket, change Ticket Dispenser. Fatal Error – game will not continue.
“Coi”	Coin Switch	One (or both) coin switches were detected “ON”	(1) Coin is stuck (2) Bad Switch (3) Shorted Cable	Remove jammed coin. Fatal Error – Game will not continue.

SONIC SPINNER, SWITCH & OUTPUT NUMBERS

The following table summarizes the SONIC SPINNER Switch Numbers (SWxx) that can appear as part of the Error Code for a stuck switch. Also included for reference are Output Numbers (OP#). The Switch and Output numbers correspond to references as shown on the SONIC SPINNER Schematic. Unused Switch and Outputs numbers are shown as '-----'.

SW #		OP#	
00	Player Stop SW	0	Player Stop Lamp
01	Index Opto	1	-----
02	Sector Opto	2	-----
03	-----	3	-----
04	-----	4	Display Tickets Lamp
05	-----	5	Display Credits Lamp
06	-----	6	-----
07	-----	7	-----
08	-----	8	-----
09	-----	9	-----
10	-----	10	-----
11	-----	11	-----
12	-----	12	-----
13	-----	13	-----
14	-----	14	-----
15	-----	15	-----
16	Service - START	16	Tickets LOW Lamp
17	Service - UP	17	-----
18	Service - DOWN	18	-----
19	Tickets LOW SW	19	Ticket Motor Enable
20	Bill Acceptor Pulse	20	Coin-In Counter
21	Coin-In Left	21	Tickets Paid Counter
22	Coin-In Right	22	-----
23	Ticket Notch	23	-----
24	-----	24	-----
25	-----	25	-----
26	-----	26	-----
27	-----	27	-----
28	-----	28	-----
29	-----	29	-----
30	-----	30	-----
31	-----	31	-----

6. Parts and Part Numbers

6.1. Exploded Drawing of Mechanism with Part Numbers

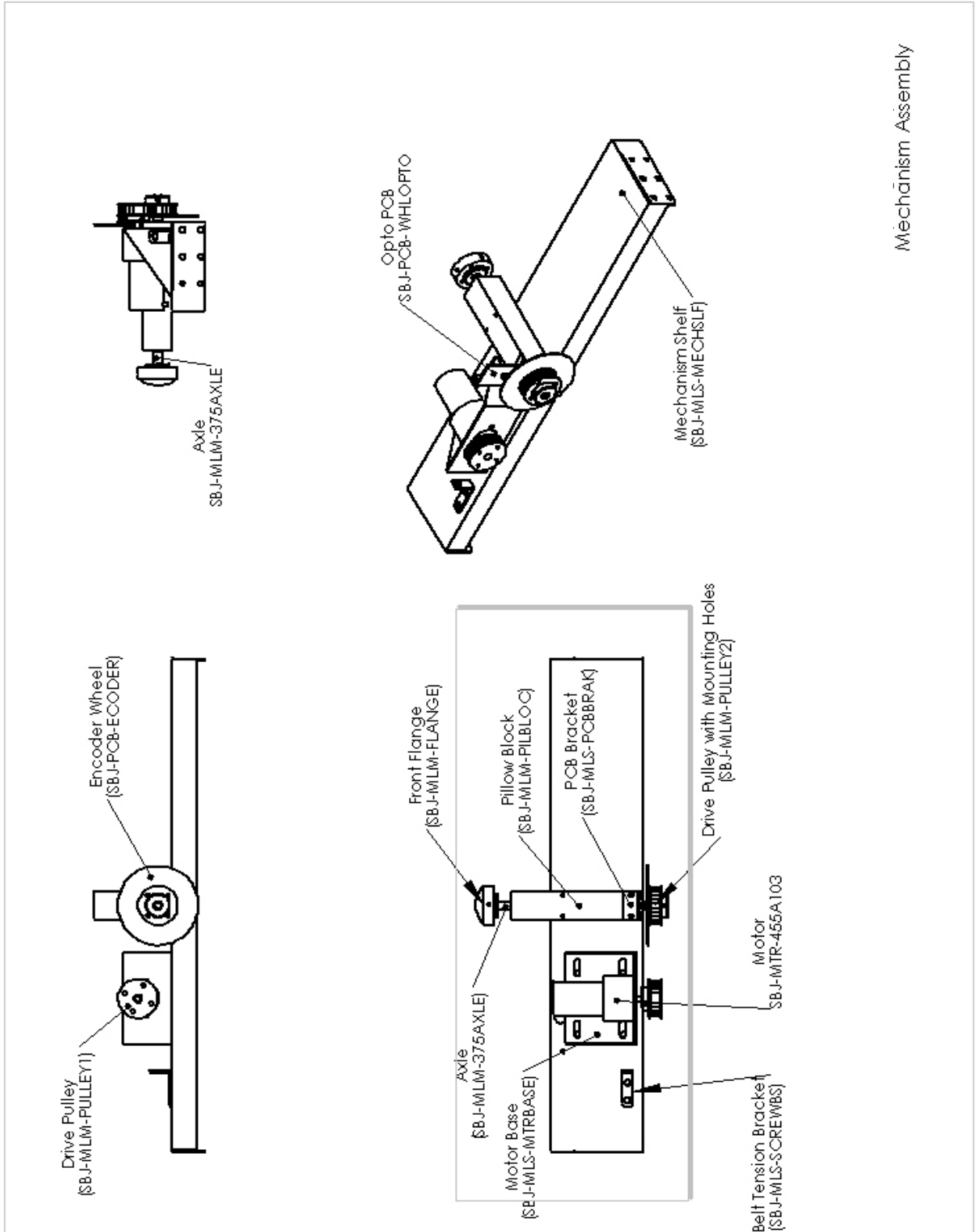

6.2. Main Cabinet with Parts Numbers

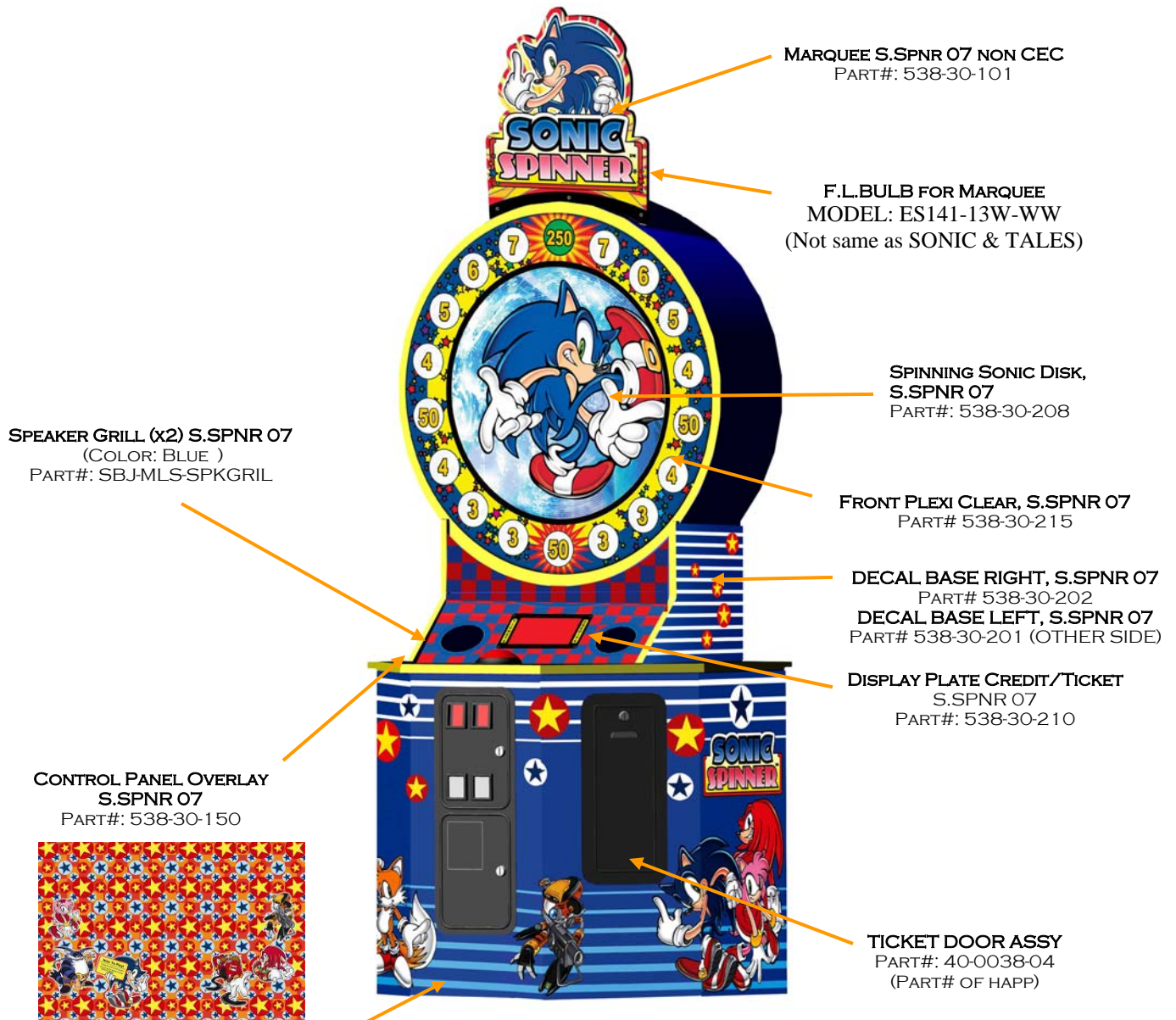

FRONT PANEL DECAL, S.SP NR 07
PART#: 538-30-200



7. Parts and Parts number

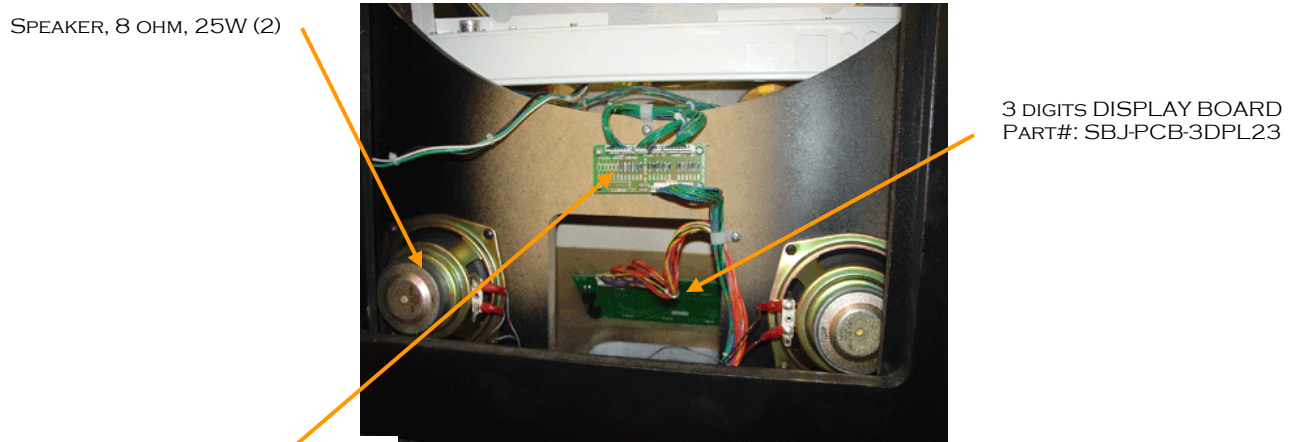
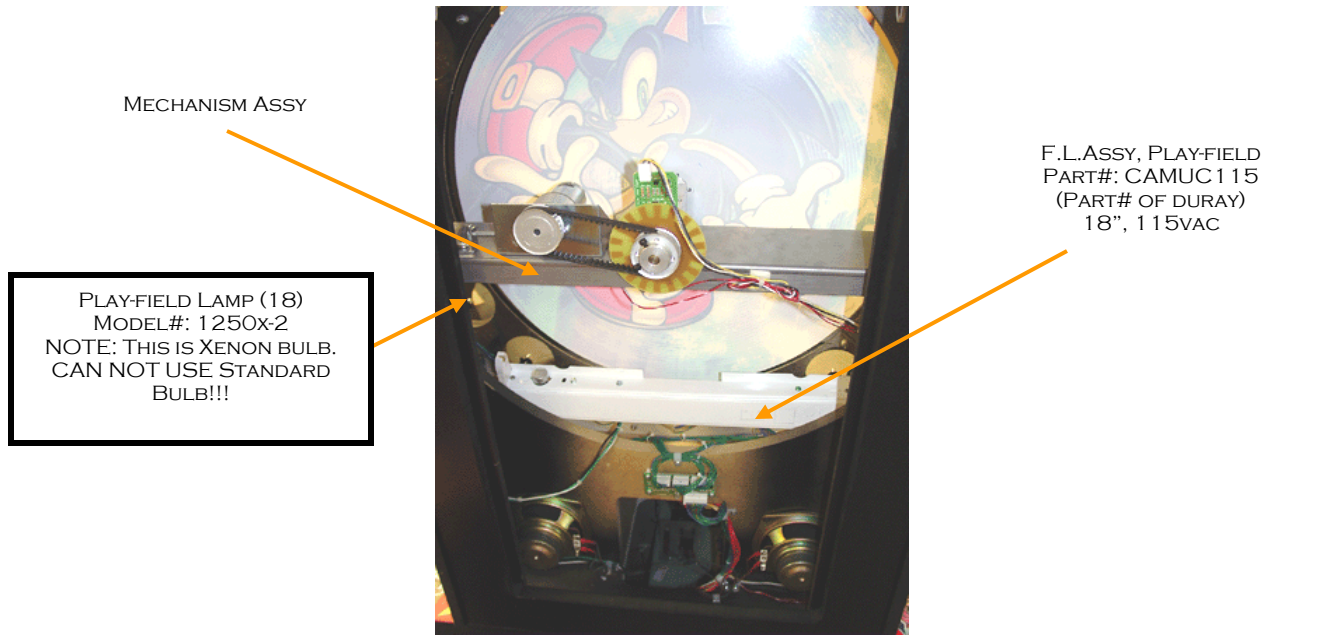

Lamp Diode PCB
Part#:
SBS-PCB-LMPDIOD

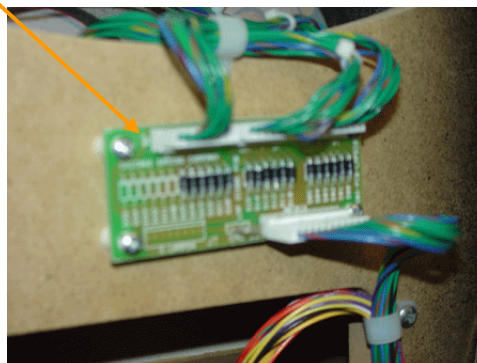

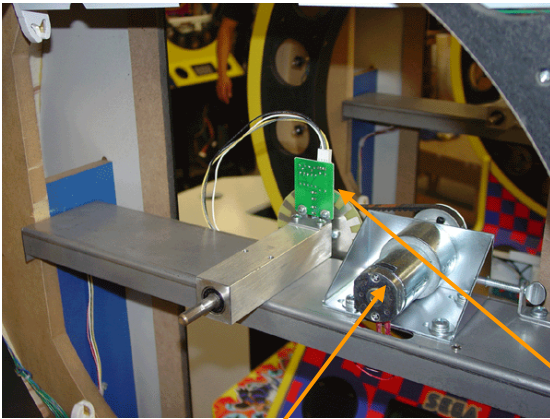

MOTOR
PART#: MTR-455A103

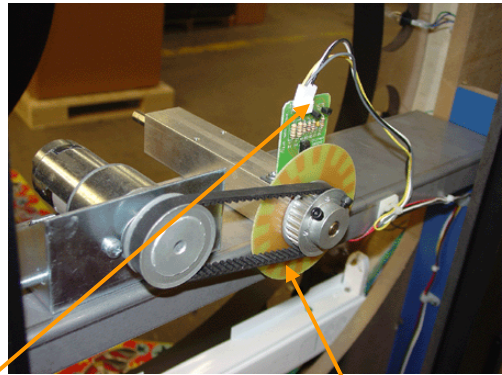

BELT
(MODEL#: 350 5m 09)

OPTO. SENSOR BOARD
PART#: SBJ-PCB-WHLOPTO

MAIN PCB
PART#: 104-0050 (HAPP)



POWER SUPPLY
24VDC (5A), 12VDC (5A)
CAPACITOR = NRSA222M25V
PART#: UP-45 OT44-0600

TICKET DISPENSER
(DELTRONICS) MODEL#: DL-1275

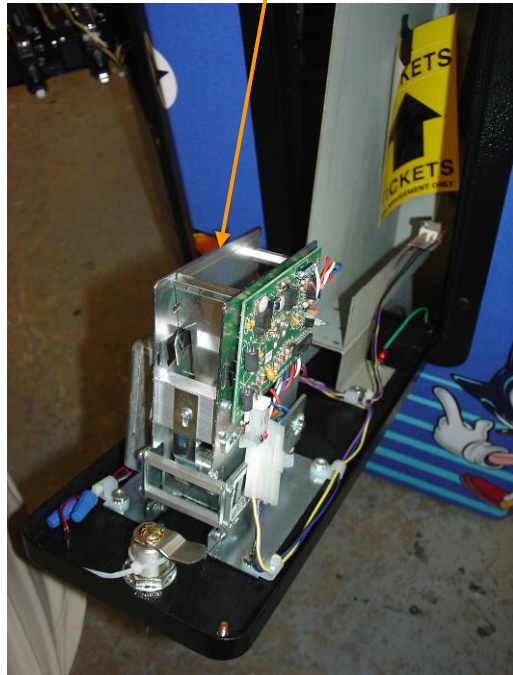



3 DIGITS DISPLAY BOARD
PART#: SBJ-PCB-3DPL23

PUSH BUTTON
PART#: 95-4002-15ZL
(PART# OF HAPP)

For Technical Assistance and parts, please call
SEGA Amusements U.S.A., INC.
at (888)877-2669